

USING SIMPLER ALGORITHM FOR CAVITY FLOW PROBLEM

S. Hosseinzadeh^{1*}, R. Ostadhossein², H.R. Mirshahvalad³ and J. Seraj⁴

^{1,2,3}Department of Mechanical Engineering, West Tehran Branch, Islamic Azad University, Tehran, Iran

⁴Department of aerospace engineering, Sharif University of Technology, Tehran, Iran

ABSTRACT

Selecting compute nodes and solution grid generation are the first steps of numerical solutions. The most distinct manner is storing the values of dependent variables in the same set of nodes and using the identical control volumes for all variables. Such a grid is called Collocated. Collocated grid arrangement has many positive results in problems with complex solving range, especially with discontinuous boundary conditions. But this arrangement was not used for a long time for incompressible flow due to pressure and velocity isolation problems and creation of fluctuations in pressure. So the researchers in the mid-60s, have developed a new arrangement to reduce this isolation and increase the coupling between pressure and velocity. This new arrangement called staggered grid, provided the field of a new method for solving fluid flow problems called SIMPLE (Semi-Implicit Method for Pressure-Linked Equation) algorithm [1]. This report presents the solution to the continuity, Navier-Stokes equations. Standard fundamental methods like SIMPLER and primary variable formulation have been utilized. The results were analyzed for standard CFD test case- cavity flow. Different Reynold number (1000, 3000) and grid sizes with the finest meshes ie. (100×100), (1000×1000) have been studied.

KEYWORDS

Navier-Stokes equations, SIMPLER algorithm, CFD, cavity flow

1. INTRODUCTION

Several popular books on computational fluid dynamics have discussed the SIMPLE algorithm in details [1, 2]. In computational fluid dynamics (CFD), SIMPLE algorithm is a widely used numerical method to solve the Navier-Stokes equations [3]. SIMPLE algorithm is an acronym for Semi-Implicit Method for Pressure Linked Equations and it was developed by Prof. Brian Spalding and his student Suhas Patankar at Imperial College, London in the early 1970s [4]. Since then it has been widely used by several researchers to solve different kinds of fluid flow and heat transfer problems. A modified variant is the SIMPLER algorithm (SIMPLE Revised), that was introduced by Patankar in 1979 [5]. The SIMPLER method is an extension of the SIMPLE method. The SIMPLE method normally gives good velocity corrections; however, the correction of the pressure is less accurate. This is as a result of the omission of the term $\sum a_{nb}u_{nb}$. The SIMPLER method keeps the algorithms for computing the velocity-corrections, but utilizes another algorithm for computing the pressure [6].

Several numerical methods for solving the 2D Navier-Stokes equation in the literature were tested utilizing the 2D cavity flow problem. In this study, SIMPLER algorithm was used with primitive variables velocity and pressure. The application of simpler iterative techniques to solve the Navier-Stokes equations might result to slow convergence. The rate of convergence is also generally strongly dependent on parameters such as Reynolds number and mesh size [7]. In this article, the results obtained by running the written code are presented in FORTRAN. It should be noted that Tecplot software has been used to process the results.

2. THE SIMPLER METHOD

SIMPLER algorithm (modified SIMPLE, Patankar (1980)) is a modified version for SIMPLE. In this algorithm, continuity equation has been used to derive a discrete equation for the pressure instead of pressure correction equation in the SIMPLE method. So the average pressure field is obtained directly and without the use of correction. But the velocities would be obtained by velocity correction with SIMPLE method.

Thus, the momentum equation is rewritten in the following discrete form.

$$u_{i,j} = \hat{u}_{i,j} + \frac{\Delta y}{a_{p,x_{i,j}}} (P_{i-1,j}^c - P_{i,j}^c)$$

$$v_{i,j} = \hat{v}_{i,j} + \frac{\Delta x}{a_{p,y_{i,j}}} (P_{i,j-1}^c - P_{i,j}^c)$$

Where are defined at unrealistic velocities of \hat{u} and \hat{v} as follows:

$$\hat{u}_{i,j} = \frac{\sum a_{nb} u_{nb}}{a_{p,x_{i,j}}}$$

$$\hat{v}_{i,j} = \frac{\sum a_{nb} v_{nb}}{a_{p,y_{i,j}}}$$

Substituting $u_{i,j}$ and $v_{i,j}$ in continuity equation and finally the equation algebraic operations, the following pressure equation is obtained.

$$q_p P_{i,j} = q_e P_{i+1,j} + q_w P_{i-1,j} + q_n P_{i,j+1} + q_s P_{i,j-1} + \hat{b}_{i,j}$$

In which the coefficients are obtained from the relations.

$$q_e = \Delta y / a_{p,x_{i+1,j}}$$

$$q_w = \Delta y / a_{p,x_{i,j}}$$

$$q_n = \Delta x / a_{p,y_{i,j+1}}$$

$$q_s = \Delta x / a_{p,y_{i,j}}$$

$$q_p = q_e + q_w + q_n + q_s$$

$$\hat{b}_{i,j} = \hat{u}_{i,j} \Delta y - \hat{u}_{i+1,j} \Delta y + \hat{v}_{i,j} \Delta x - \hat{v}_{i,j+1} \Delta x$$

Solution process in SIMPLER method is very similar to the process of solving in SIMPLE method, the difference is that the pressure distribution in the SIMPLER method is not guessed, but is obtained with the pressure equation. Another difference is that, at the end of a reputation, only the velocities are modified and no correction is considered for pressure.

2.1. Motivation of the SIMPLER

The approximation introduced in deriving the P' equation (the omission of the term $\sum a_{nb}u'_{nb}$) leads to rather exaggerated pressure corrections, therefore under relaxation becomes necessary. Since the influence of the neighbor-point velocity corrections is eliminated from the velocity-correction formula, the pressure correction has the whole burden of correcting the velocities, and this leads to a rather severe pressure-correction field. If the pressure-correction equation is only applied for the task of correcting the velocities and provide some other means of obtaining an improved pressure field, then a more efficient algorithm can be constructed. This is the essence of SIMPLER [1].

2.2. Algorithm of the SIMPLER

The revised algorithm includes solving the pressure equation to obtain the pressure field and solving only the pressure-correction equation to correct the velocities. The steps in the solution are as follows [8]:

1. Act with a guessed velocity field.
2. Calculate the coefficients for the momentum equations and hence calculate u^{\wedge}, v^{\wedge} .
3. Calculate the coefficients for the pressure equation and solve it to obtain the pressure field.
4. Solve the momentum equations to obtain u^*, v^* .
5. Calculate the mass source b and hence solve the p' equation.
6. Correct the velocity field, but do not correct the pressure.
7. Return to step 2 and repeat until convergence.

2.3. Flow Chart of the SIMPLER

In this algorithm, the discretized continuity equation is applied to derive a discretized equation for pressure, instead of a pressure correction equation as in SIMPLE [9]. Therefore the intermediate pressure field is directly obtained without using a correction. Velocities are however, still obtained by the velocity corrections of SIMPLE [10].

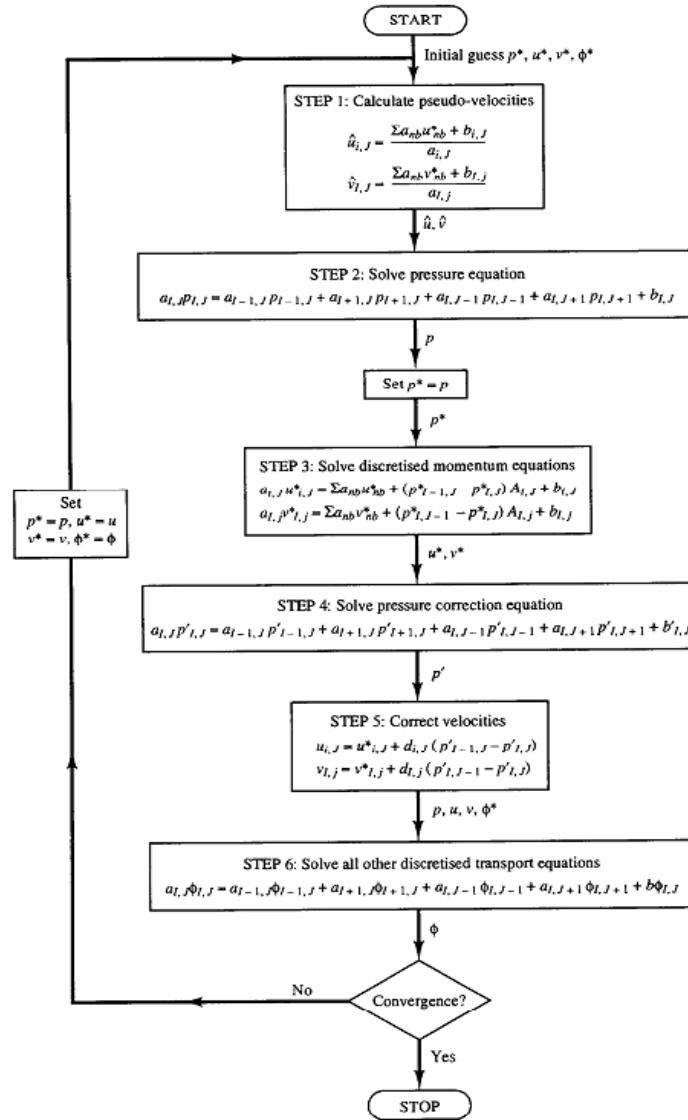

Flow chart 1. Showing the SIMPLER algorithm

3. PROBLEM DEFINITION

The problem considers incompressible flow in a square domain (cavity) with an upper lid moving with a velocity ($u=1$ ft/s) and the other boundaries have no-slip tangential and zero normal velocity boundary condition as depicted in Fig.1 [7]. The main objective is to obtain the velocity field in 2D incompressible steady state flow with different Reynold number (1000, 3000) and distinct grid sizes (100×100), (1000×1000). Nowadays, primitive variable formulation is preferred.



Figure 1. Cavity flow in a square domain [7]

3.1. Governing Equations

The governing equations are those of 2D incompressible Navier-Stokes equations, continuity and u and v momentum equations (1, 2, 3).

$$\nabla \cdot (\rho \mathbf{V}) = 0 \quad (1)$$

$$\nabla \cdot (\rho \mathbf{V}u) = \nabla \cdot (\mu \nabla u) - \nabla p \cdot i + S_u \quad (2)$$

$$\nabla \cdot (\rho \mathbf{V}v) = \nabla \cdot (\mu \nabla v) - \nabla p \cdot j + S_v \quad (3)$$

The difficulty in solving these equations is that the NS equations are nonlinear and the pressure in the domain is unknown [11]. The continuity and momentum equations are also decoupled partial differential equations and need to be solved.

3.2. Numerical Method Discretization

Co-located storage of the pressure and velocity variables at the cell centers leads to the problem of checker boarding. This is because the cell center values of pressure and velocity were cancelled out on expanding the face gradient terms. To overcome this problem, staggered grid was utilized for discretization of the momentum equations. The staggered grid for the u momentum equation is depicted in Fig.2 alongside the neighboring velocity vectors for calculating velocity gradients. Staggered grid in vertical direction is applied for v momentum equation. Pressure is stored on the original grid and the pressure difference terms are evaluated as a difference of cell center pressure values.

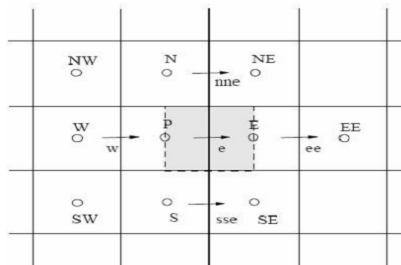

Figure 2. Neighbors for U_e momentum control volume

3.3. Discretization of boundary cells

Although, the velocity boundary condition is applied when calculating gradients in the first cell using the staggered grid for the u-momentum discretization, it does not consider momentum balance on the boundary strip (Fig.3). The last (far east) staggered cell is also only half Δx thick.

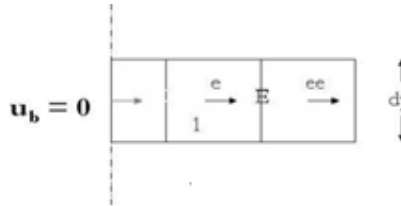

Figure 3. Neighbors for U_e momentum control volume

4. RESULTS

A uniform grid is assumed in the x and y direction. The momentum equations are discretized and the SIMPLER algorithm is implemented. Several grid sizes have been studied and for different Reynold numbers (1000, 3000). The graphs include computed u-velocity along the vertical center line and v- velocity along the horizontal center line [7]. Here the plots show results of the finest meshes ie. (100×100) and (1000×1000). In addition, the stream lines have been plotted for each Re value and were compared to the stream lines. Figures 4 and 5 show the velocity plots for Re=1000, Grid 100× 100. Apart from a primary vortex, the formation of secondary vortices can be seen on the corners of the domain.

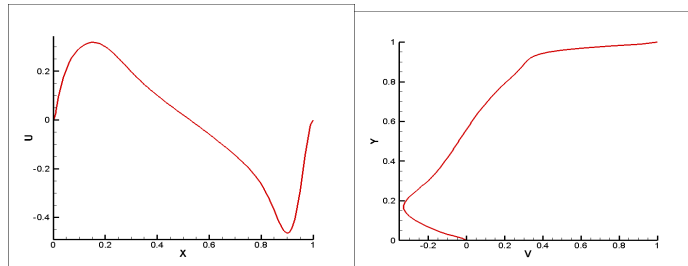

Figure 4. Re =1000 U& V velocity, Grid100× 100

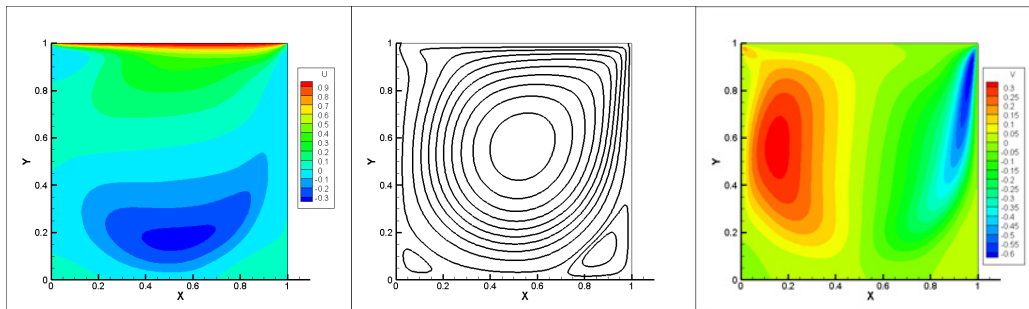

Figure 5. Re =1000 Streamlines, Grid 100× 100

Figures 6 and 7 show the results for higher Re of 3000 and Grid 100×100. In addition, for higher Re values, the primary vortex shifts more towards the center of the domain. The results for other Re can also be seen below. For higher Re values, the primary vortex shifts more to the center and more corner secondary vortices are formed. The secondary vortices are also convected towards the center of the domain for higher Re values. Also with the convection of secondary vortices, more vortices are formed at the corners.

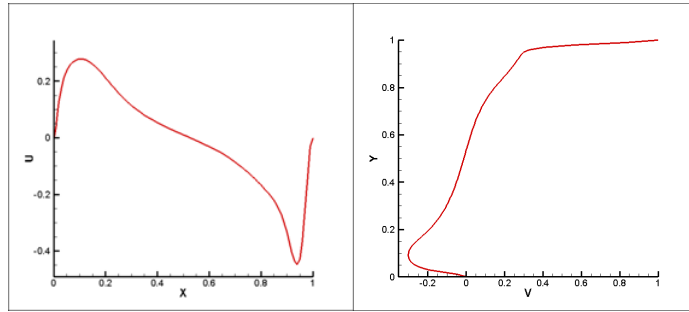

Figure 6. Re =3000 U & V velocity, Grid 100× 100

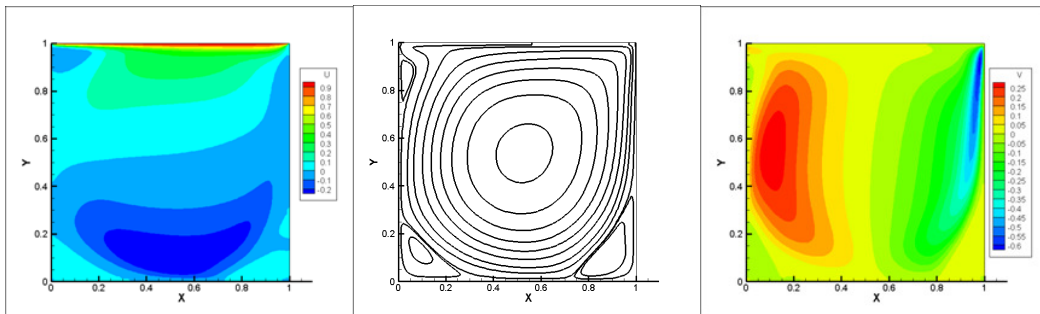

Figure 7. Re =3000 Streamlines, Grid 100× 100

The stream line function plots for various Grid 1000× 1000 can be verified with the plots shown in Appendix A. Figures 8, 9 and 10 show the stream line contours in the reference paper. We can see a very close resemblance with the computed stream line solutions with SIMPLE method. [12].

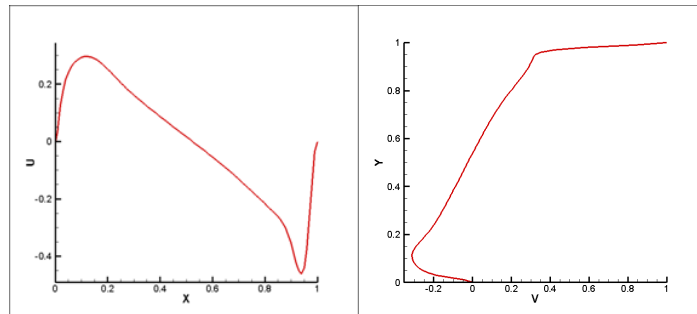

Figure 8. Re =3000 U & V velocity, Grid 1000× 1000

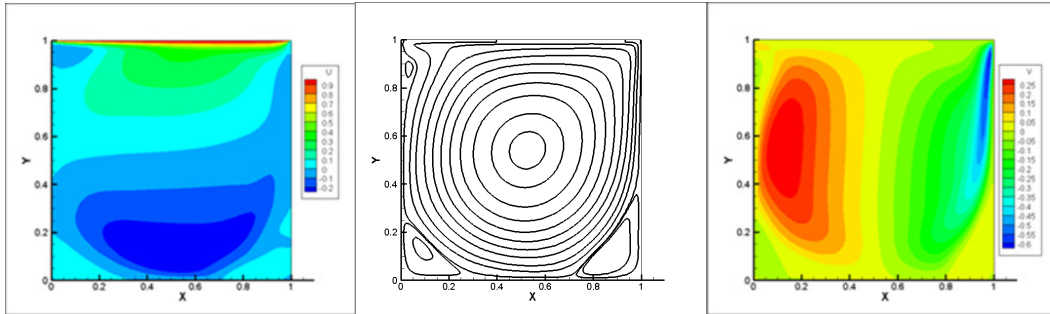

Figure 9. $Re = 3000$ Streamlines, Grid 1000×1000

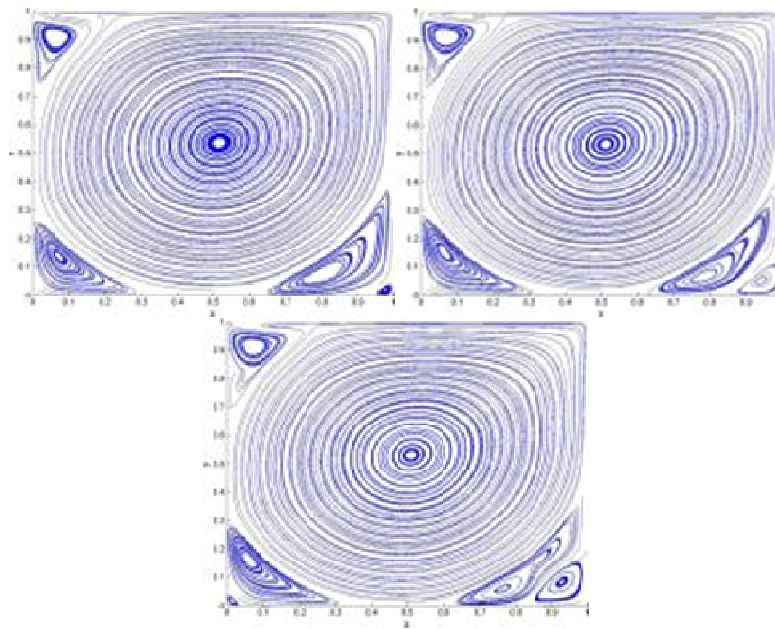

Figure 10. In order from left to right: $Re = 5000$, $Re = 7500$, $Re = 10000$ Streamlines, Grid 150×150

4. CONCLUSION

Comparing the results of this study with those of the benchmark paper on driven cavity flow show that SIMPLER solver is adequate to solve complex flow field problems like the cavity flow. There is a good match of the computed results with the reference values. Fine details like the corner vortices were also accurately predicted using fine grids. Other than some minor computational difficulties, the SIMPLER solver is very efficient in solving flow problems. The accuracy and convergence might be increased using refined technique like SIMPLE-C though. But why this method is better than SIMPLE technique?!

5. DISCUSSION

It is easy to see that, for the one-dimensional problem discussed in this study, the SIMPLER algorithm would immediately give a converged solution. Generally, since the pressure-correction equation produces reasonable velocity fields, and the pressure equation works out the direct consequence (without approximation) of a given velocity field, convergence to the final solution should be much faster. In SIMPLE, a guessed pressure field plays a prominent role. On the other hand, SIMPLER does not use guessed pressures, but extracts a pressure field from a given velocity field. If the given velocity field happens to be the correct velocity field, then the pressure equation in SIMPLER will produce the correct pressure field, and there will be no need for any further iterations [13]. If on the other hand, the same correct velocity field and a guessed pressure field were used to initiate the SIMPLE procedure, the situation would actually deteriorate at first. The use of the guessed pressure would lead to starred velocities that would differ from the given correct velocities. Then, the approximations in the p' equation would produce incorrect velocity and pressure fields at the end of the first iteration. Convergence would take several iterations, despite the fact that we did have the correct velocity field initially [1]. Although SIMPLER has been found to produce faster convergence than SIMPLE, it should be emphasized that one iteration of SIMPLER involves more computational effort. First, the pressure equation must be solved in addition to all the equations solved in SIMPLE; and second, the calculation of u , v and w represents an effort for which there is no counterpart in SIMPLE. However, since SIMPLER requires lesser iterations for convergence, the additional effort per iteration is more than compensated by the overall saving of effort [1].

REFERENCES

- [1] Patankar, S. V. (1980). Numerical Heat Transfer and Fluid Flow. Taylor & Francis. ISBN 978-0-89116-522-4.
- [2] Ferziger, J. H. Peric, M. (2001). Computational Methods for Fluid Dynamics. Springer-Verlag. ISBN 978-3-540-42074-3.
- [3] https://en.wikipedia.org/wiki/SIMPLE_algorithm.
- [4] Ferziger, J. H. Peric, M. (2001). Computational Methods for Fluid Dynamics. Springer-Verlag.
- [5] Tannehill, J. C. Anderson, D. A. Pletcher, R. H. (1997). Computational Fluid Mechanics and Heat Transfer. Taylor & Francis.
- [6] Nils Reidar B. Olsen. CFD Algorithms for hydraulic engineering. Department of Hydraulic and Environmental Engineering. The Norwegian University of Science and Technology, (December 2000).
- [7] Vaidehi A. SIMPLE SOLVER FOR DRIVEN CAVITY FLOW PROBLEM, Copyright c by ASME.
- [8] <http://www.cfd-online.com/Forums/main/62684-quick-algorithm.html>.
- [9] Vujicic R. M. HEFAT2014, 10th International Conference on Heat Transfer, Fluid Mechanics and Thermodynamics, Orlando, Florida, 14 – 16 July 2014.
- [10] H K Versteeg and W Malalasekera. An Introduction to Computational Fluid Dynamics the Finite Volume Method 2nd Edition. Bell & Bain Limited, Glasgow. (Second edition published 2007).
- [11] Karna Patel.; Numerical Simulation of 2D Lid Driven Cavity Flow using SIMPLE Algorithm Copyright by ASME. Mark as interesting Comment
- [12] U.Ghia, K N Ghia and C.T . Shin. High Re solutions for Incompressible flow using the Navier-Stokes equations and a Multigrid method. Journal of computational physics 48, 387-411, 1982.
- [13] <http://www.cfd-online.com/Forums/main/13432-no-cells-iterations-converge-print.html>.